

Information Sheet # 47

Remote Radiator Systems for Generator Sets

Your Reliable Guide for
Power Solutions

1.0 Introduction:

Engine driven generator set systems traditionally utilize a radiator and fan for transferring the heat from the engine coolant. While many generator sets have an engine mounted radiator and cooling fan, it is quite common for larger sets, particularly those located inside, to use a remote radiator system.

This information sheet discusses systems that benefit from a remote radiator and its proper installation.

2.0 The following factors can influence system designer to select a Remote Mounted Radiator System:

Space considerations - When the generator location has a limited footprint the radiator system can be mounted remotely, such as a roof location.

Noise - For a generator set located in an area subject to noise restrictions, as the radiator fan is a principal noise source, remote mounting the radiator can take the fan noise away from the noise sensitive area.

Ventilation - The generator installation, especially an inside location, requires adequate ventilation in order to provide sufficient air for cooling, combustion, and removal of radiated heat from the generator set. When there are limitations to the amount of air that can be discharged into and from the generator location, remotely mounting the radiator allows a 50% drop in the quantity of air required in the generator room. *(Continued over)*

Diagram One - Remote Radiator Cooled System Layout

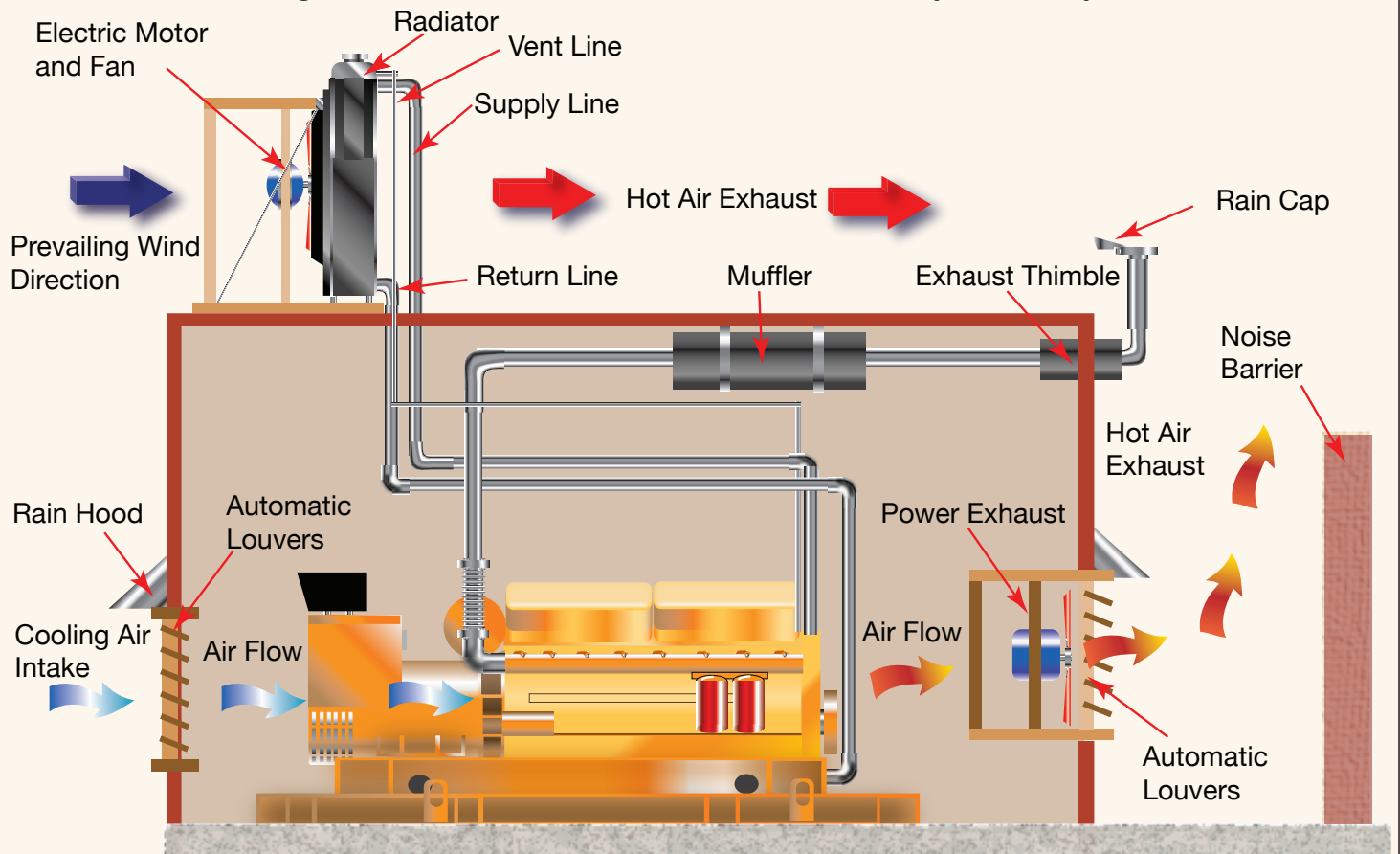

To fulfill our commitment to be the leading supplier in the power generation industry, the RP Power teams ensure they are always up-to-date with the current power industry standards as well as industry trends. As a service, our **Information Sheets** are circulated on a regular basis to existing and potential power customers to maintain their awareness of changes and developments in standards, codes and technology within the power industry.

Diagram Two - Remote Cooling With Split Core Radiator

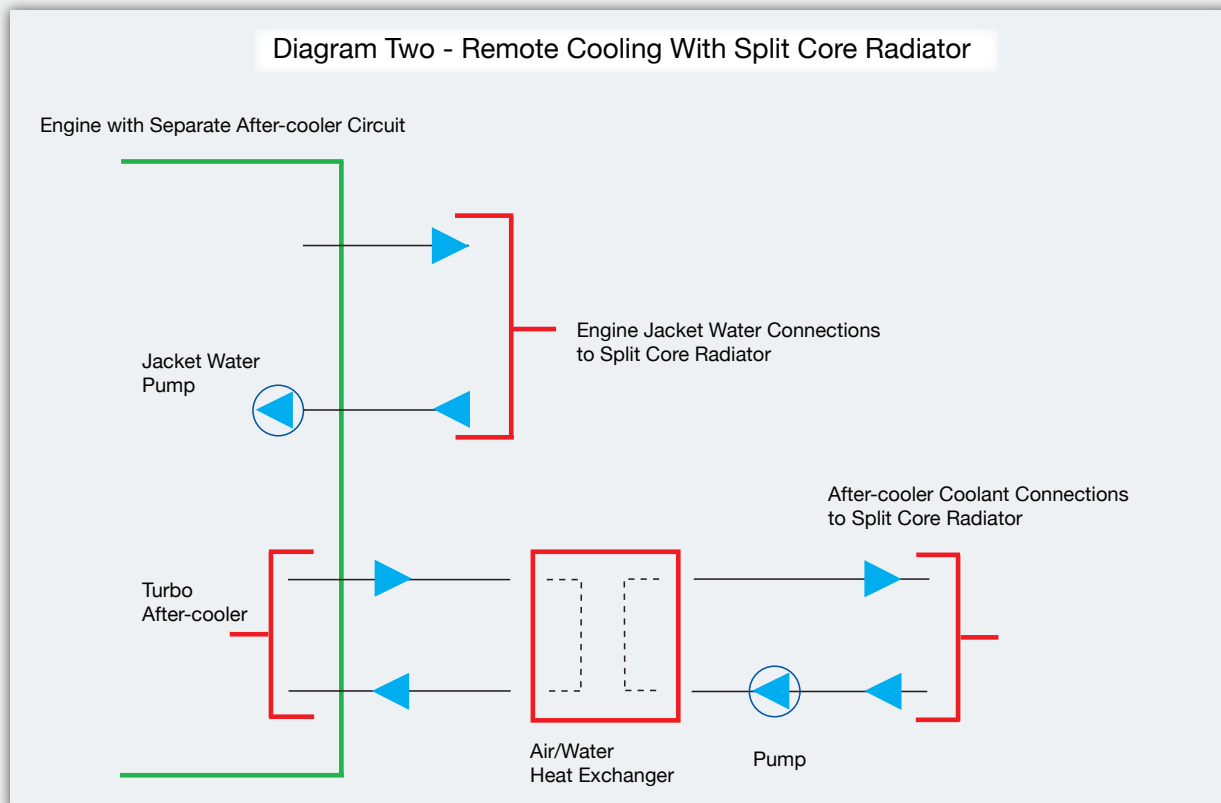

3.0 Generator systems most commonly installed with remote radiators:

While a remote radiator can be fitted to many systems for stationary applications, the option is usually only economically and engineering practical on systems above 500kW. Remote radiators on smaller sets tend to be special applications.

4.0 Principal considerations when installing a remote mounted radiator system:

A remote radiator system, unlike a generator set that comes from the manufacturer with the radiator installed on the base, requires the final assembly of the cooling system to be undertaken on site. It requires specialist knowledge regarding sizing, pipe dimensions, radiator types and sizes, mounting, loading, etc, to install and should only be undertaken by qualified personnel. Your local distributor should be consulted regarding the correct installation.

5.0 The following summarizes installation issues to be considered:

Coolant piping - Pipe lengths and the engine manufacturer's requirements for coolant flow will determine the diameter of the piping. Connections to the engine should have flexible pipe sections to avoid engine vibration being transmitted to the piping system. (see Diagram One)

Radiator selection - Radiators are available with single and split cores. Split cores allow for the cooling of two systems; selection should be made as follows:

Single core - If the generator set engine is naturally aspirated or has a turbo charger that is not cooled.

Split core - Many larger generator sets and those that most commonly require remote radiator systems incorporate turbo after-coolers. After-coolers use air/water heat exchangers and require an additional core in the radiator (split core) to cool the turbo after-cooler coolant. (see Diagram Two for a schematic of a split core radiator for a turbo after-cooler)

Pumps - The engine manufacturer incorporates a pump to manage the coolant flow to a radiator mounted adjacent to the engine. A remote radiator system will be much further from the engine and can require an additional pump to ensure adequate coolant flow. For radiators mounted above the engine such as on a roof, the installer will have to know the required lift of the pump in addition to the flow requirement.

When a split core radiator is used for an after-cooler, an additional pump will be required for the after-cooler coolant. (see Diagram Two)

Generator room ventilation - While remotely mounting the radiator will remove a high percentage of the air flow require out of the generator set location, the system designer still has to calculate the ventilation requirements to manage radiated heat and combustion. (see Diagram One)



Little Rock, AR
7777 North Shore Place
North Little Rock, AR 72118
Ph: 501.568.3000
Fx: 501.604.3033

Memphis, TN
10100 Vista Cove
Olive Branch, MS 38654
Ph: 833 RP Power
Fx: 901.386.4944

Oklahoma City, OK
14615 Metro Plaza Blvd.
Edmond, OK 73013
Ph: 405.548.5228
Fx: 405.752.4241

Tulsa, OK
1111 N. 105th E. Place
Tulsa, OK 74116
Ph: 918.960.6000
Fx: 918.960.6001

www.rppower.com

info@rppower.com

KOHLER
IN POWER. SINCE 1920.